



DON'T FORGET
 These instructions can be found in color and expandable at QA1.net

Technical Support Line: (952) 985-5675
 Email: sales@QA1.net

WATCH THIS INSTALLATION ON:
 **YouTube**

INSTALLATION INSTRUCTIONS

QA1 P/N

52340-x400 through 52348-x400 '62-'76 Mopar Front Coil-over Conversion System
 52832 ('62-66 A-body), 52833 ('67-'76 A-body), 52834 (B & E body) Front Sway Bar

TOOLS AND SUPPLIES REQUIRED

- Floor Jack
- Two (2) Jack Stands
- SAE Wrench Set
- Anti-seize
- Ratchet & SAE Socket Set
- Torque Wrench
- Engine Hoist
- Ball Joint Separator

PRE-INSTALLATION NOTES:

Some big-block applications will need a mid-sump oil pan, as stock oil pans can interfere with the steering rack.

394 c.i. Small-block oil pans will not provide enough steering rack clearance on A-body cars with this suspension.

Gen3 Hemi-swapped cars can use a rear-sump truck oil pan with custom headers, or the Milodon 31000 with TTI headers. The Milodon pan will use Milodon pick-up 18331 on pre-2008 engines and pick-up 18341 on 2009 and later Gen 3.

Which oil pans are compatible with QA1 coil-over suspension systems?

Chassis	LA Small Block	B/RB (383/440) *	426 HEMI	Gen 3 HEMI
62-66 A-Body	Rear sump	Rear sump	N/A	N/A
67-76 A-Body	Rear sump or stock mid sump	Milodon 31580	Milodon 31580	Rear sump Mopar 77072450AB, Mid Sump Milodon P/N 31000
62-65 B-Body	Rear sump	Rear Sump	Rear Sump	Rear sump Mopar 77072450AB
66-72 B-Body	Rear sump or stock mid sump	Kevco P/N M315 Milodon 31580, Milodon 30930, 30931	Kevco P/N M315 Milodon 31580, Milodon 30930, 30931	Rear sump Mopar 77072450AB, Mid Sump Milodon P/N 31000
70-74 E-Body	Rear sump or stock mid sump	Kevco P/N M315 Milodon 31580, Milodon 39030	Kevco P/N M315 Milodon 31580, Milodon 39030	Rear sump Mopar 77072450AB, Mid Sump Milodon P/N 31000
D100	'72-'93 D Series rear sump pan, Milodon 30981,30986	'72-'93 D Series rear sump pan	'72-'93 D Series rear sump pan	Rear sump, Mopar P/N 77072450AB

* Stud Girdles on B/RB will require pan modifications.

* Mopar 77072450AB truck oil pan kit hangs about 1" below the bottom of the car K-members. Milodon 31000 is flush or just above the bottom of the K-member.

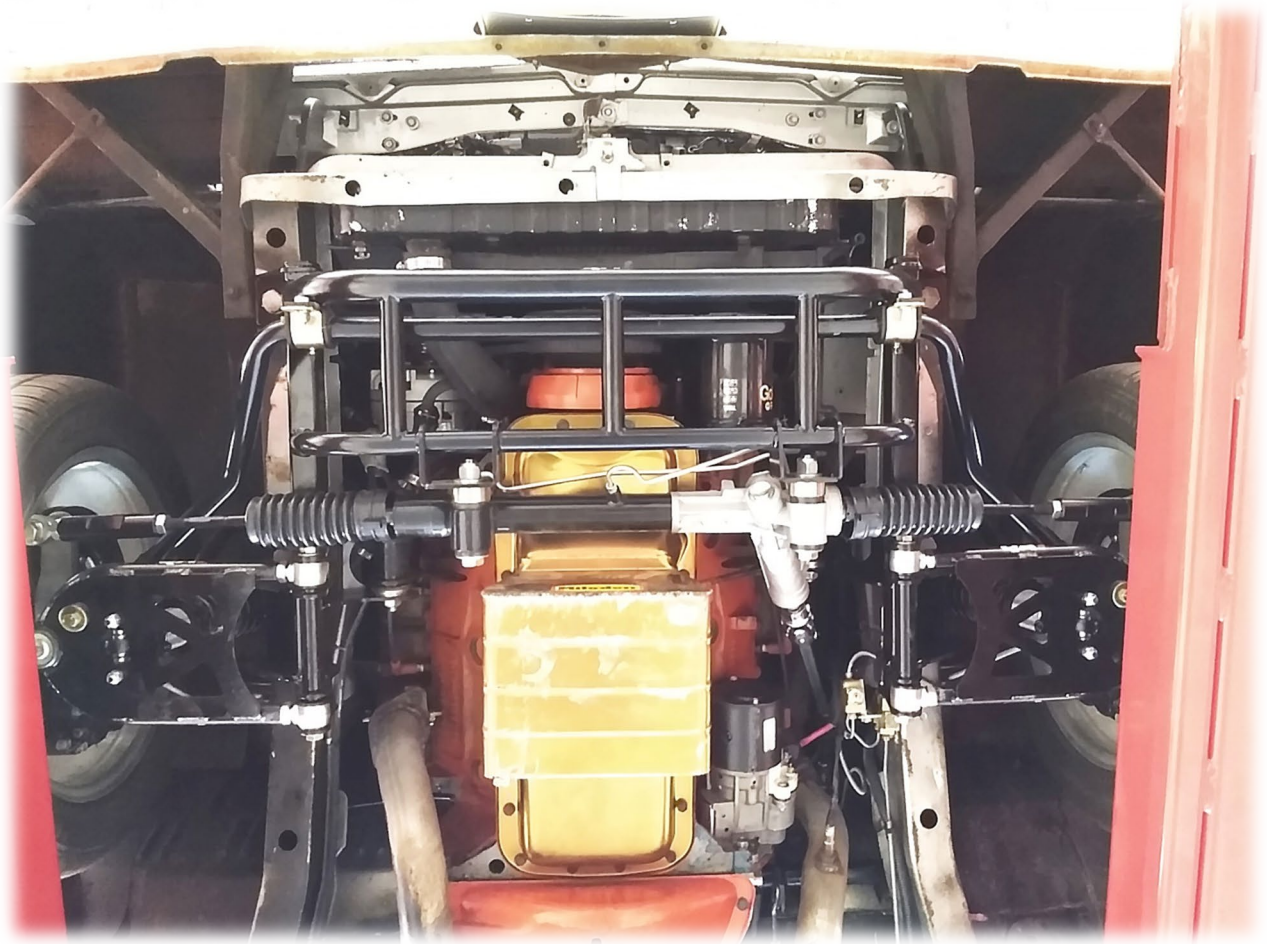

DISASSEMBLY

1. Measure and record the vehicle ride height at the center of the wheel opening. This will help set the ride height after installing the front suspension system.
2. Lift and support the vehicle on a solid surface. Support the car by the frame rails, allowing the suspension to droop. A vehicle lift is best, but jack stands can work as well.
3. Remove the front wheels and tires.
4. Remove the shocks and front sway bar.
5. Remove the pressure on the torsion bars by loosening the adjuster bolts in the lower control arms.
6. Remove the snap ring at the rear of the torsion bar (**Figure 1**). Slide the torsion bar back and out of the car. (**Figure 2**). Loosen the lower control arm pivot shaft and gently pry the control arm back to help remove the torsion bar.



Figure 1

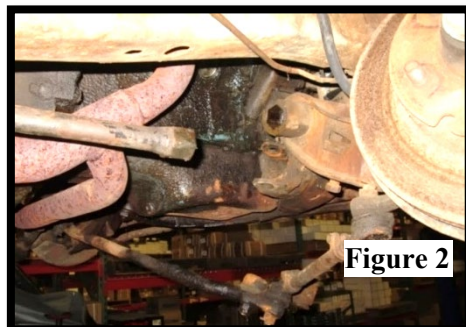

Figure 2

7. Remove the cotter pin from the lower ball joint. Loosen the castle nut, but do not remove. Separate the lower control arm from the ball joint and then remove the nut.
8. Remove the steering rods by disconnecting the tie rods from the spindles, the pitman arm, and the idler arm.
9. Remove the steering shaft from the steering box. The steering box will not need to be removed from the k-member for this installation.
10. Remove the strut rods from the k-member and lower control arm connections.
11. Locate the factory bump stops on both sides of the frame rails. There will be two bump stops per side. Remove the bump stops by drilling out the spot welds. **(Figure 3)** After removing the bump stops, touch up the frame using paint or undercoating to prevent corrosion.
12. Unbolt the engine mounts from the k-member.
13. Support the engine using an engine hoist from the top or, if using a lift for the installation, a transmission jack from below.



Figure 3

DO NOT CONTINUE UNTIL THE WEIGHT OF THE ENGINE IS OFF THE K-MEMBER.

14. Unbolt the four k-member mounting bolts and remove from the car. Retain these bolts as they will be used to mount the new K-member.
15. Remove the engine mounts from the engine.
16. Remove both upper control arms from the frame.
17. Ensure the threads in the frame and the k-member mounting bolts are clean and free of debris.



ASSEMBLY

1. If using a big block requiring a mid-sump oil pan, install the pan with the correct oil pickup tube.
2. Using the factory k-member bolts, lift the new k-member into place and mount it to the frame. Torque to 150 lb. ft.
3. Identify the left and right-side engine mount indicated by the manufacturer's stickers.

4. Loosely install the engine mounts to the engine block, reusing the factory hardware.
5. The engine mounts will attach to the k-member using 9/16" x 6.5" long bolts with one 9/16" washer under the bolt head and one 9/16" washer under the Nylock nut. Four 5/8" washers per side are also included so that the engine mounts can be adjusted front to back. Start with two washers on the front side of the mount and two on the back side, and reposition the washers as needed to best align the engine in the engine bay. **(Figure 4)**
6. With the engine in position, torque the engine mount hardware to 55 lb. ft. The 9/16" hardware connecting the engine mount to the k-member should be torqued to 75 lb. ft.
7. Slowly release the engine support once the hardware is torqued.

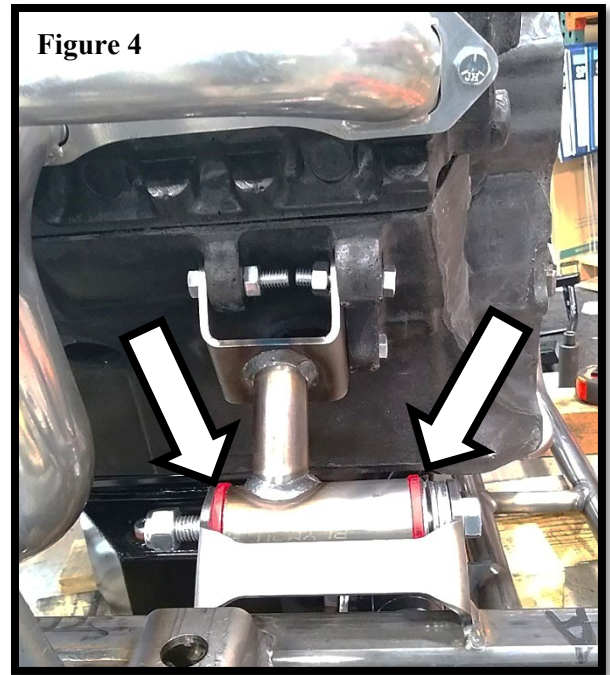

NOTE:

QA1 makes multiple sets of engine mounts for easy engine swaps. You can find the orientation for each mount set below.

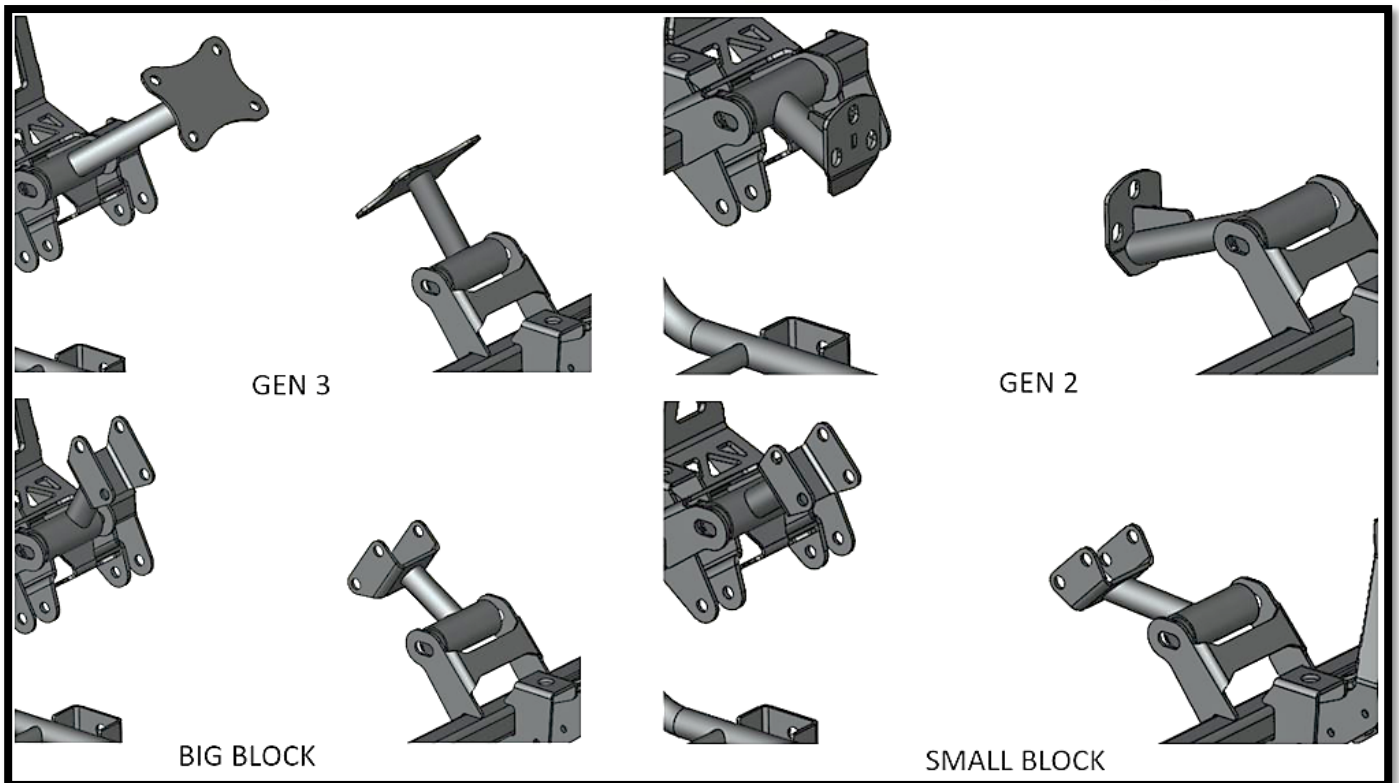

NOTE:

On some A-bodies, there will be extra material on the rear lip of the front upper control arm mount. This does not apply to all A-bodies. If this additional material is present, it will need to be notched in the rearward part of the mount 3/8" on both sides of the vehicle to allow full motion of the new control arm.



UPPER CONTROL ARMS

8. Identify the Driver (left) and Passenger (right) upper control arms by the stickers placed on the arms. In the correct position, the arms can also be identified by the front connection being higher than the rear connection. **(Figure 5)**

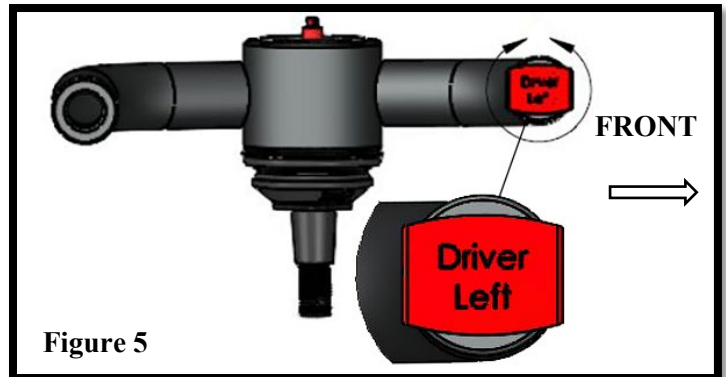

9. In preparation for installing the upper control arm, thread the 5/8" jam nuts onto the 5/8" male threaded rod ends. Thread the jam nut so that two threads are showing between the jam nut and the head of the rod end. **(Figure 6)**

10. Apply anti-seize to the threads of the rod end and thread them into the upper control arms. Leave the jam nuts loose until the arms are installed to allow alignment with the mounting bolts.

11. Mount the upper control arm to the factory mounting points with two 5/8" wide spacers per connection. Fasten the arm to the factory mounts using a 1/2" x 4" bolt with two washers per connection and a Nylock nut. Torque to 50 lb. ft. **(Figure 7)**



Figure 6

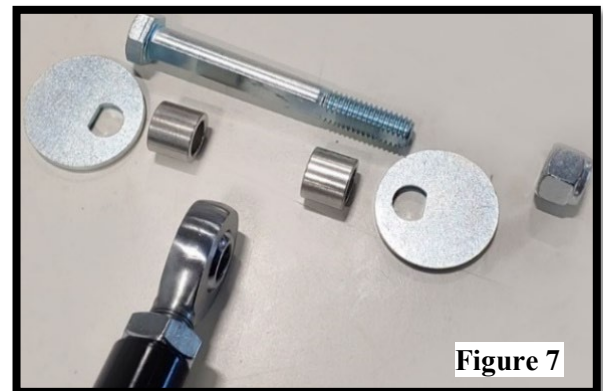

Figure 7

LOWER CONTROL ARMS

NOTE:

The Street Performance suspension comes with poly bushings for the lower control arm mounts. The Drag Racing suspension comes with rod ends for the lower control arm mounts. Installation of either mounting style follows the same procedure.

The lower control arms for this suspension are driver/passenger-neutral and work on either side of the car.

12. Assemble the included bushings and sleeves into the rod end (Street Performance kit only) **(Figure 8)**

13. Thread one 5/8" jam nut onto the 5/8" threaded rod end (drag kit) or 5/8" rod end bushing (Street Performance Kit). **(Figure 8)**

14. With anti-seize applied to the threads, thread the rod end into the lower control arm to the jam nut until approximately seven threads are showing between the jam nut and the rod end. **(Figure 11)** Leave the jam nuts loose until the arms are installed to allow alignment with the mounting bolts.

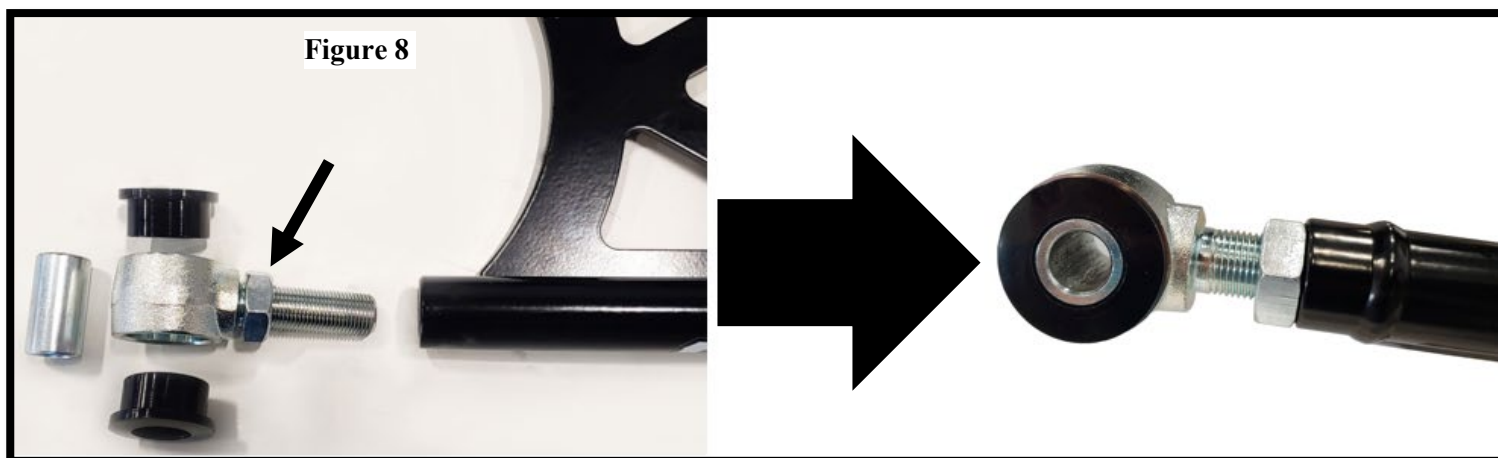

15. Mount the control arms to the k-member using 1/2" x 3" mounting bolts with one washer under the bolt head and one washer under the nut. Drag kits using rod ends for the pivot point will need one 7/16" spacer on the front side of each connection and one 3/8" spacer on the rear position of each connection. Torque to 50 lb. ft.

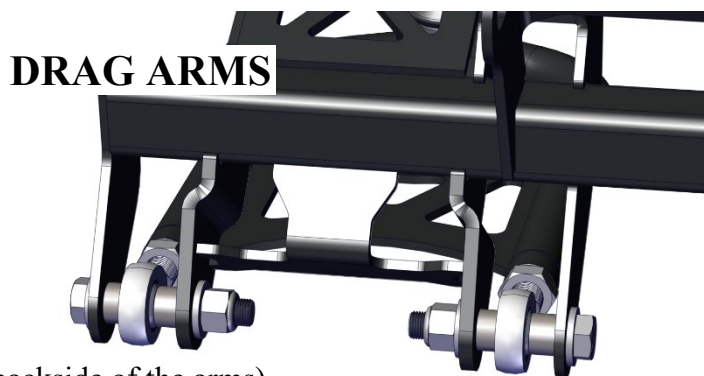
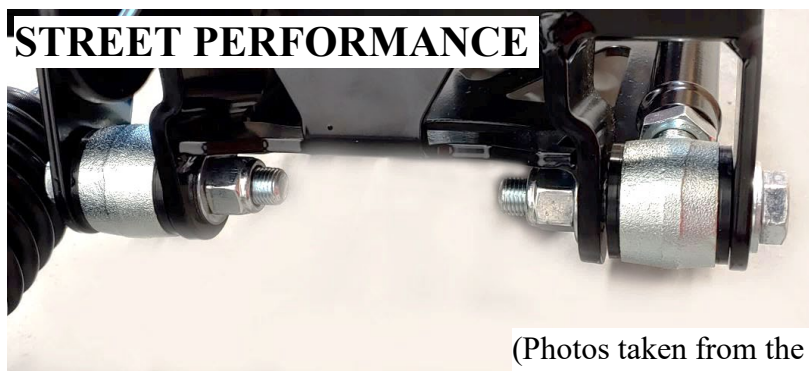

(Photos taken from the backside of the arms)

STEERING RACK

NOTE:

The power rack included with this suspension system needs the included rack extension kit installed ON ALL B & E BODY CARS before installation. A-body cars **DO NOT** use these rack extensions. **(See step 16)**

IF CONVERTING TO MANUAL STEERING:

The mounting is different for manual and power steering racks. QA1 crossmember is drilled with mounting holes for the power steering rack, and pilot holes are present for the manual rack location.

To convert to a manual steering rack, you will need to drill out the pilot holes to 5/8" diameter. The hole on the driver's side will overlap the power rack mounting hole. Use a step drill bit on this hole to avoid catching the drill bit in the original hole.

The manual rack to use is Speedway Motors part# 91034344, and the rack extension kit needed (**B & E Body Only**) is Speedway part# 910-34345-MAN. This manual rack will use a different input spline and will need a 9/16", 26 spline U-joint. (Speedway Motors part number 91032290)

16. Remove the dust boots from the steering rack.
17. Run the steering rack out on the geared end and place it in a vice. **(Figure 9)** The geared end of the rack does not pass through any seals. DO NOT PUT THE SMOOTH END OF THE SHAFT IN THE VICE OR DAMAGE THE TEETH ON THE RACK
18. Remove the tie rod ends by unthreading them. The tie rods will be tight. Using a lever through the rack mount will help gain leverage on the tie rod.

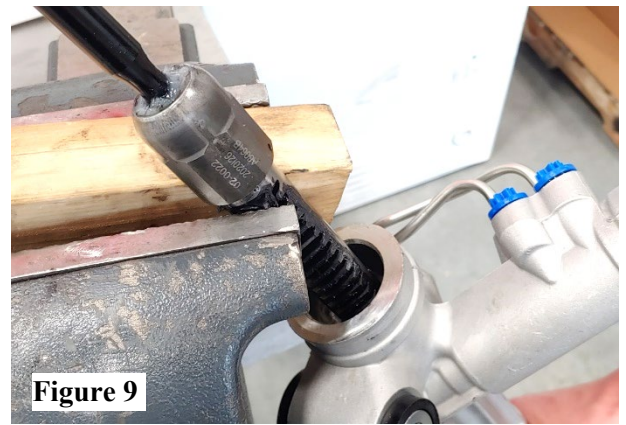
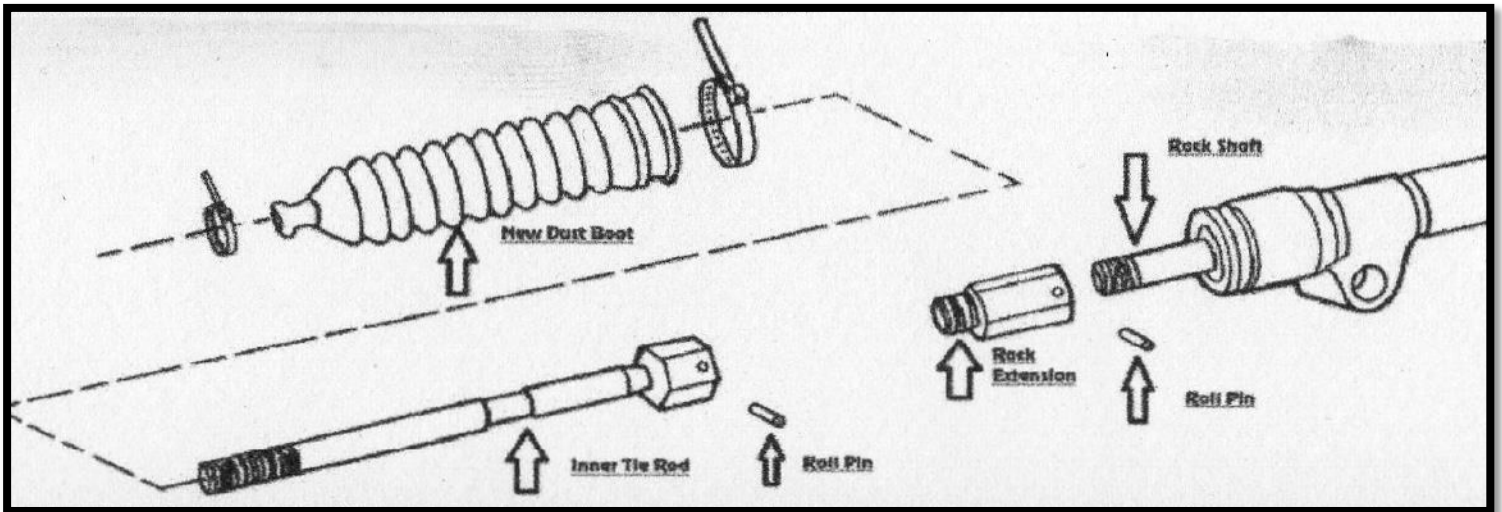

Figure 9



19. Using a small amount of red Loctite, thread the rack extensions onto the rack.
20. With a small amount of red Loctite, reinstall the inner tie rod onto the rack extension.
21. Once the rack extensions are installed on both sides of the rack, install the new dust boots and secure them with ties. **(Figure 10)**

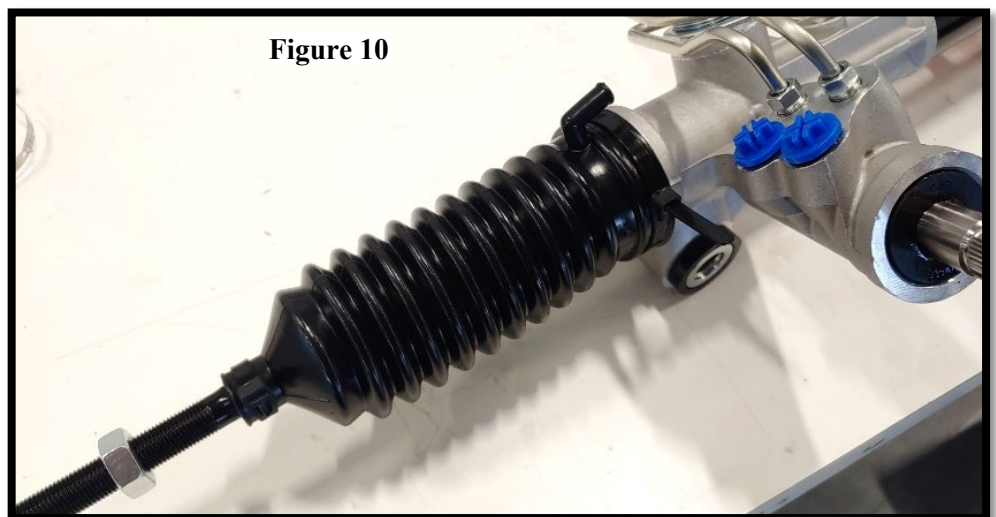

Figure 10

For B & E Body Cars Only

Due to variations in the overall length of the rack-and-pinion, the inner tie rod ends may need to be shortened to achieve proper toe settings. For **B- and E-body cars**, after the rack extensions are installed, take a width measurement to determine whether the rack needs to be narrowed.

With the tie rods level, measure end-to-end as shown in **Figure 11**. If the overall length is greater than 49.2", cut the inner tie rod ends equally to get 49.2" overall length. Install the jam nuts onto the tie rods, then make the cuts with a metal hacksaw or a cut-off wheel. Once cut, clean the threads at the cut mark with a file, then unthread the jam nuts to clean them. Proceed with the remainder of the install.

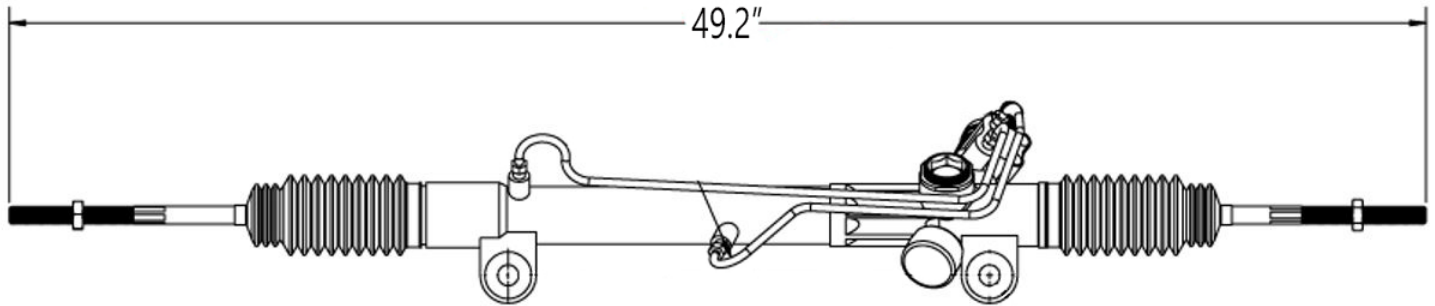

Figure 11

22. Install the power rack to the cross-member with one 3/4" wide rack spacer between the rack and k-member. (**Figure 12**) Attach using 5/8" x 4.5" hardware with one 5/8" I.D. x 1.75" washer on the rack bushing side and one 5/8" I.D. x 1.25" washer on the k-member side of the mount. Torque to 90 lb. ft.

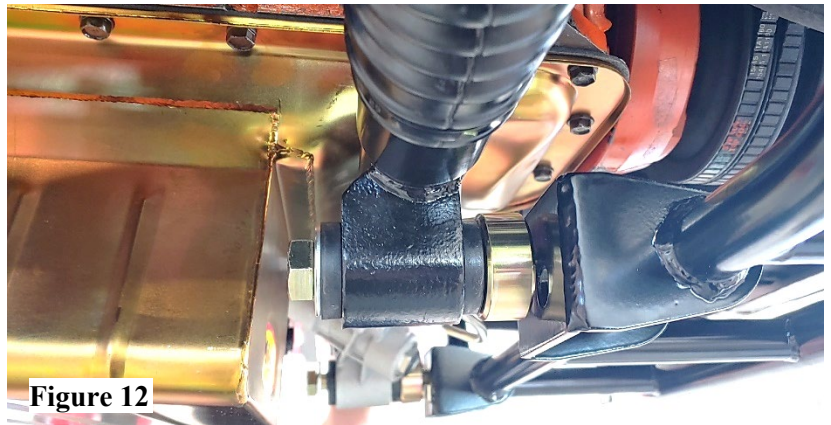

Figure 12

COIL-OVERS

23. Refer to the coil-over assembly instructions included with your shocks and assemble the spring onto the shock.

NOTE:

The Dx415 shocks that come with this Mopar suspension use a single spring seat collar with a set screw and do not include a lower locking collar like many other QA1 shocks.

24. Install the upper shock connection with one .250" beveled spacer on each side of the shock eyelet, with the smaller beveled edge facing the shock bearing. (**Figure 13**) Secure to the crossmember using 1/2" X 3" hardware with two washers and a Nylock nut. Torque to 50 lb. ft.

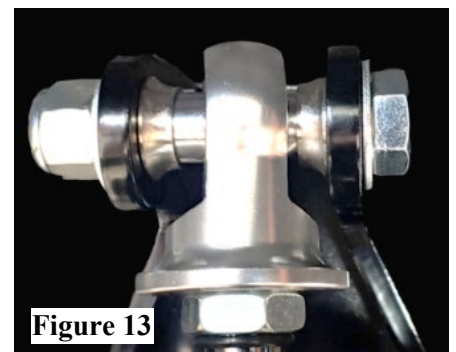
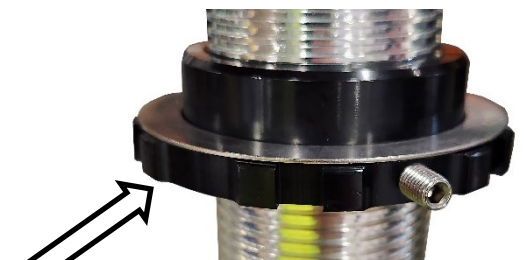

Figure 13

25. Install the lower shock connection to the lower control arm with the shock adjustment knobs towards the wheel/tire using the included 3/8" x 1.25" hardware and Nylock nuts. Torque to 31 lb. ft. **(Figure 14)**



SPINDLES/BRAKES

NOTE:

In some applications using the Mustang II spindle **(Figure 14A)** and Wilwood brake system, slight variations will require that the boss **(Figure 14B)** on the inside of the spindle (facing the engine) be ground or filed down (marked in yellow). This adjustment is necessary to align the caliper brackets on radial-mount disc brake kits properly. Refer to the images below for visual guidance.

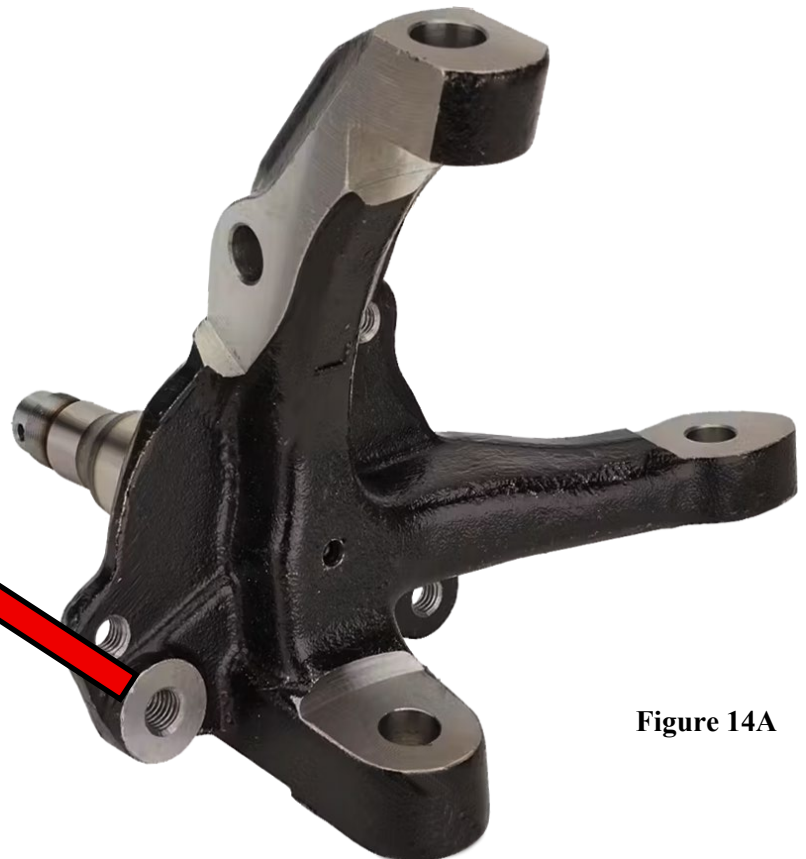
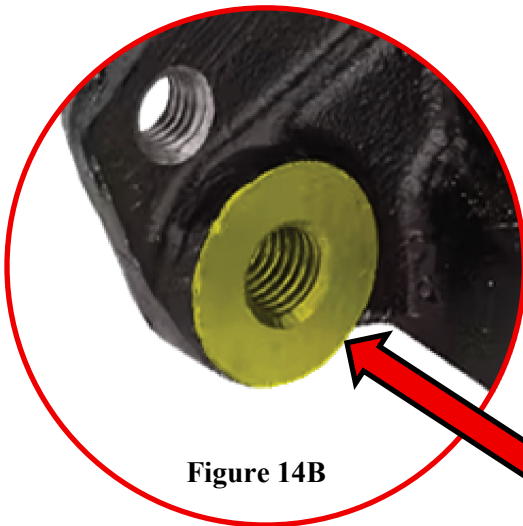

26. Install the spindles with the steering arm forward to the upper control arm using one 9/16" (.188" thick) washer on the ball joint stud, followed by the 1/2" castle nut. Torque to 55 lb. ft. Never loosen the castle nut to find the cotter pin hole. **(Figure 15)**

NOTE:

The upper control arm uses an extended upper ball joint stud for added camber gain. This extended ball joint stud will leave a portion of the stud exposed between the dust boot and the spindle. **(Figure 15)**



27. Install the lower ball joint into the spindle using one 9/16" washer and 9/16" castle nut. Torque to 65 lb. ft. Continue tightening to line up the cotter pin hole. Never loosen the castle nut to find the cotter pin hole.

28. Thread one right-hand jam nut onto the inner tie rod and one left-hand jam nut onto the XML10 left-hand male rod end.

29. Using anti-seize on the rod end threads, thread the rod end into the left-hand threaded end of the QA1 tie rod sleeve, leaving four threads visible between the jam nut and head of the rod end.

30. Thread the tie rod sleeve onto the inner tie rod until the spindle visibly appears to be at 0° toe.

31. Tighten the jam nuts to the adjustment sleeve.

Bump Steer Spacers

This suspension comes with 4" and 5" tie rod to spindle mounting bolts, 1" beveled spacer, 1/4" beveled spacer, and four 1/4" adjustment spacers per side. **(Figure 16)** To minimize bump steer, use up to 2" of spacers using the 5" bolt between the steering arm and tie rod end. **(Figure 17)** This will require at least 17" wheels to clear the tie rod. If using 15" wheels, the 1" beveled spacer with one 1/4" spacer on the 4" mounting bolt is the maximum length that will fit inside the wheel. **(Figure 18)** Vehicle ride height and caster setting will affect bump steer settings. Determine the number of adjustment spacers that will fit within the wheel diameter and consult the alignment shop for further adjustments.

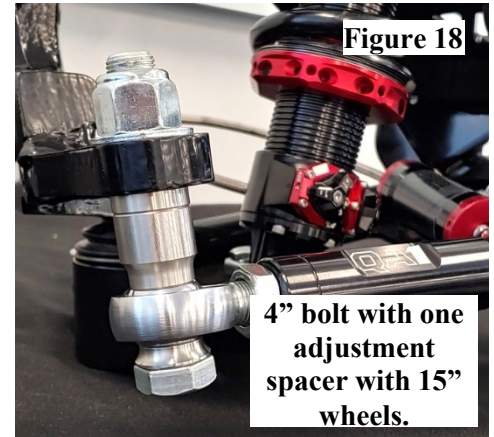
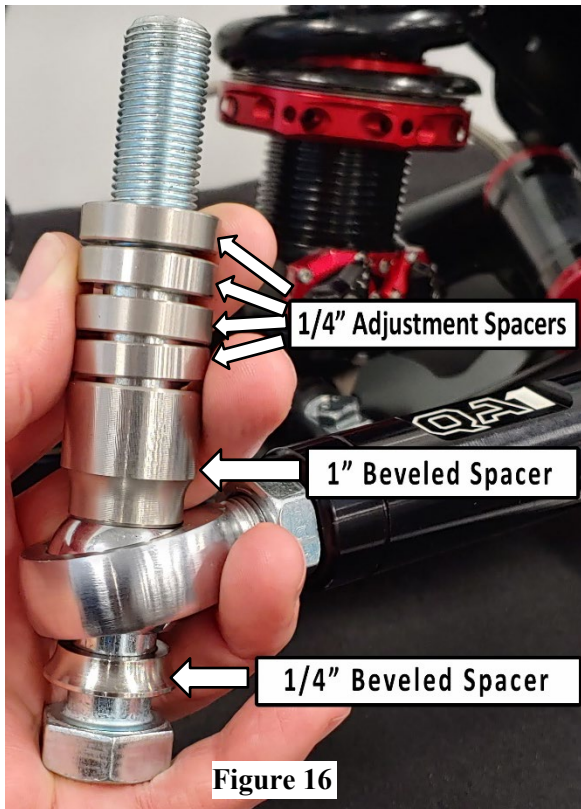

32. Determine whether the 4" or 5" long tie rod bolt will be used (based on the notes above). Attach the tie rod to the underside of the spindle with one 1/4" beveled spacer under the bolt head (narrow end of spacer towards the rod end) before inserting the bolt up through the rod end (threaded end up). Install a 1" beveled spacer between the rod end (narrow end towards the rod end) and the spindle. Determine how many 1/4" adjustment spacers to install on the bolt before inserting the bolt up through the steering arm. Install a 5/8" washer and 5/8" Nylock nut to secure. Torque to 79 lb. ft. Consult with your alignment specialist to determine if more/fewer adjustment spacers are needed.
33. Install the brake rotors and calipers according to the manufacturer's instructions. This suspension system uses standard or drop spindles based on the Mustang II.

STEERING SHAFT

NOTE:

The factory steering shaft will need to be cut and fitted with the included U-joint to begin the routing of your new steering shaft. **Where you cut the factory steering shaft will affect how you route the new steering shaft around the headers.** It is important to test fit and plan the routing of the factory steering rack to achieve this.

34. Remove the steering column from the car by unbolting the four-bolt mount on the inside of the firewall and disconnecting the column from the steering box coupling. A small pin must be removed from the coupling. The pin at the top of the coupling prevents the shaft from sliding.
35. Cut the steering shaft to the ideal length that will best route the new shaft around your engine/header and deburr.

(Figure 19)

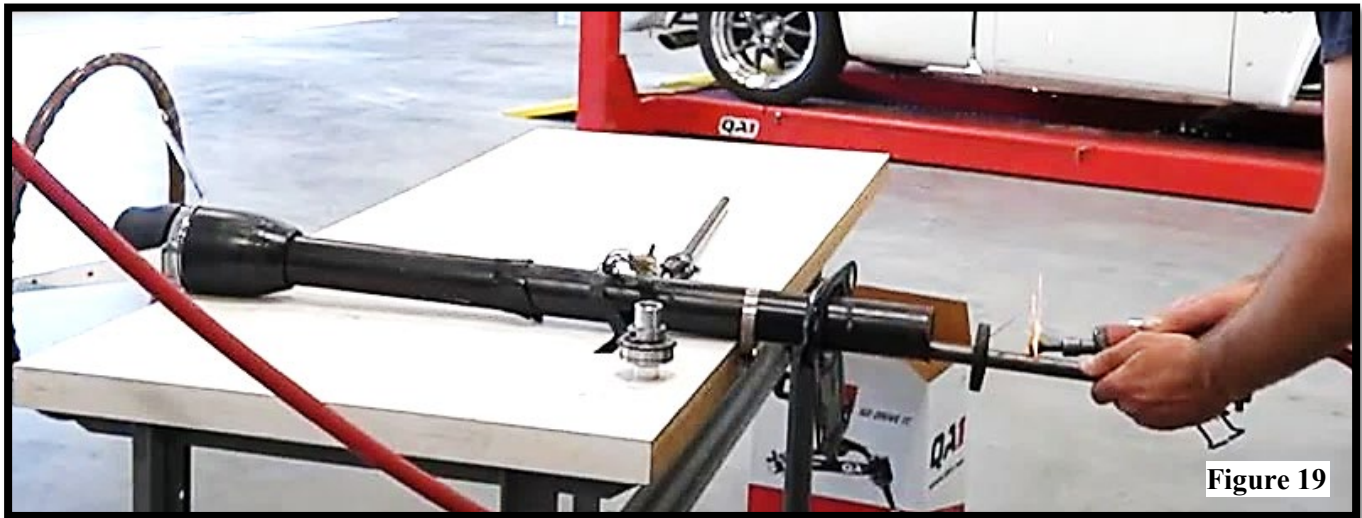

36. Install the included bearing onto the steering shaft and press it into the column housing with the Allen head bolts towards the steering rack (away from the steering wheel). **(Figure 20)** Non-collapsible steering shafts will need the included bushing inside the bearing to fit 3/4" diameter steering columns. **(Figure 21)** Collapsible steering shafts will have a 1" diameter shaft and will use the bearing only.

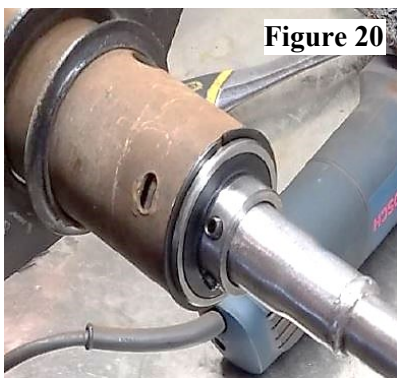

NOTE:

On some cars, 73-'76 A-bodies in particular, the steering column housing will have a small lip that prevents the bearing from being installed in the column housing. This lip will need to be removed using a Dremel or similar grinding device.

37. With the bearing pressed into the housing, torque the Allen screws to 12 lb-ft.
38. Install the smooth end of one u-joint onto the steering column and weld it into place. Use care not to overheat the joint or steering column support bearing. **(Figure 22)**
39. Reinstall the column into the car in the reverse order it was removed.



40. Install the splined end u-joint onto the steering rack with the allen screws lightly set. **(Figure 23)** The u-joints that complete the steering shaft need to be in phase. **(Figure 24)** Rotate the joints as needed before final installation.
41. Measure the distance between the u-joints, ensuring that the planned shaft length will not extend into the joint itself, which will cause binding. Cut the included steering shaft to be slightly longer than your measurement, then test-fit.
42. With the final length of the steering shaft installed and no present, set the Allen screws to 12 lb. ft.
43. Double-check all work and hardware installation before re-installing the wheels/tires.

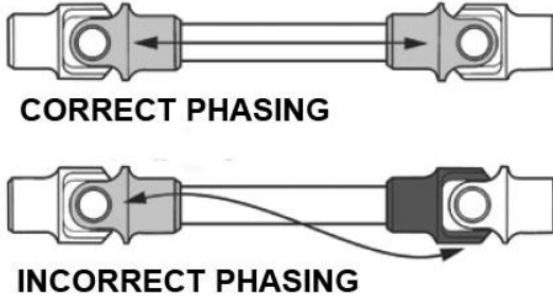

Figure 23

binding

Figure 24

Power Steering Connections

- The steering rack included with this suspension is based on a Fox body Mustang. The rack has a 9/16"-18 pressure port and 5/8"-18 return.
- Adapter fittings to convert the rack to -6 AN can be found at Speedway Motors as p/n 910-4047. Custom -6 AN hoses will be needed.
- Small block and B/RB engines- The Saginaw PS pump is a typical early OE pump that can be used. Federal & TRW-style pumps can be used on later engines. For the 5/8" inverted flair on the pressure side, use Summit Racing p/n 961947ERL to convert to -6 AN. CVF aftermarket pumps also work great with this rack.
- The factory Gen 3 Hemi pump puts out too much pressure for the included steering rack. Bouchillon Performance offers a reduced-pressure pump or can modify your pump to be used with this rack.
- PS Cooler is suggested in the return line with Gen 3 Hemi pumps or any vehicle that will see significant road course use.



Steering Rack Requirements

Operating pressure:	1,100 to 1,200 psi
Flow Rate:	1.7-2.0 g.p.m.

A PROFESSIONAL ALIGNMENT SHOULD BE PERFORMED BEFORE DRIVING THE VEHICLE

Recommended Alignment Specs

Caster	+5° to +6°
Cross Caster	±0.5°
Camber	-0.5° ±0.5°
Toe	+0.10° ±0.15° (positive is toe in)

SWAY BAR INSTALLATION

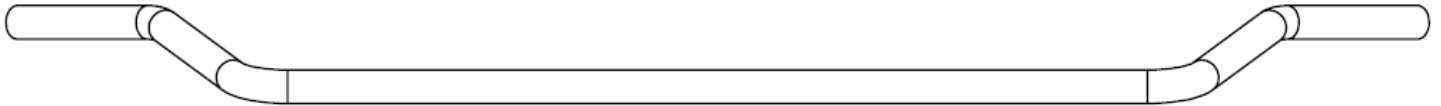

1. Install the sway bar to the control arms with the included end links. The sway bar and control arm connections will use two bushings and two washers with the sleeve separating them. **(Figures 25 & 26)** Tighten the end link until the bushings compress to the same diameter as the washers.
2. Install the frame mount bushings onto the front of the bar and mount the bar to the k-member using the included frame mounts and 3/8" hardware. **(Figure 27)** Torque to 31 lb. ft.



Figure 25

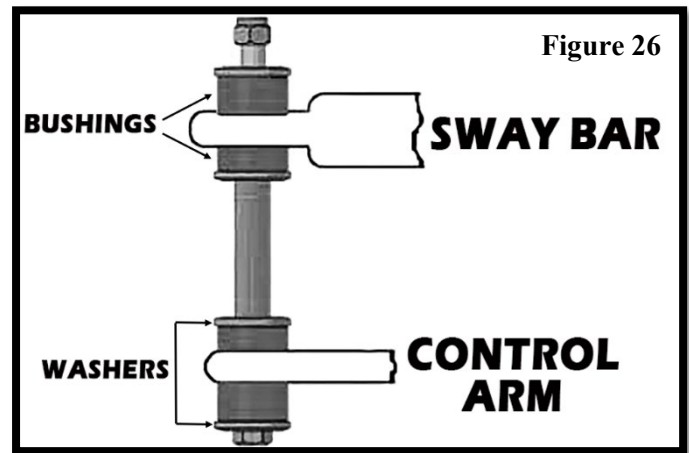

Figure 26

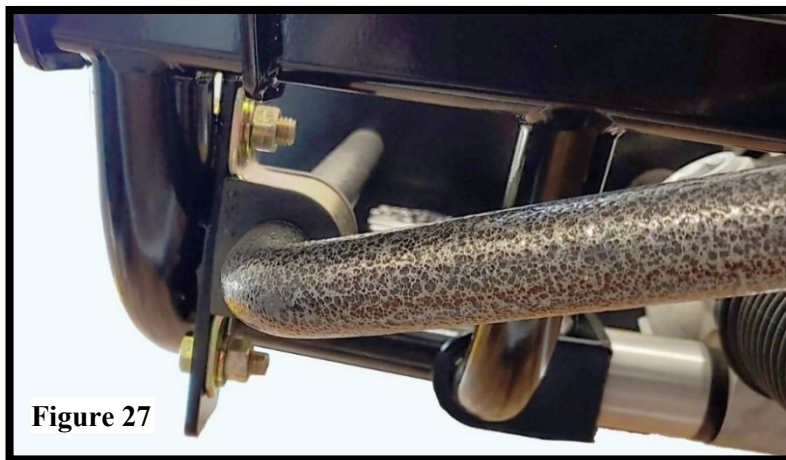
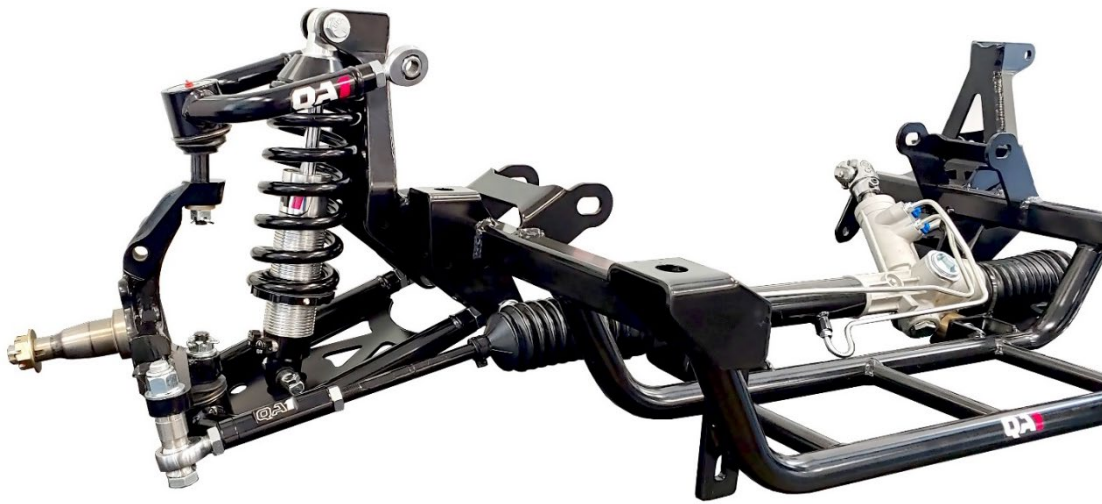

Figure 27



Technical Support Line: (952) 985-5675 Email: sales@QA1.net

READ ALL INSTRUCTIONS CAREFULLY AND THOROUGHLY BEFORE STARTING INSTALLATION. PRODUCTS THAT HAVE BEEN INSTALLED ARE NOT ELIGIBLE FOR RETURN. USE THE PROPER JACKING LOCATIONS. DEATH OR SERIOUS INJURY CAN RESULT IF INSTRUCTIONS ARE NOT CORRECTLY FOLLOWED. A GOOD CHASSIS MANUAL, AVAILABLE AT YOUR LOCAL PARTS STORE, MAY ALSO AID IN YOUR INSTALLATION.

• DISCLAIMER / WARRANTY •

QA1 WARRANTS THAT THE PRODUCTS WILL BE FREE FROM DEFECTS IN MATERIAL AND WORKMANSHIP FOR ONE YEAR FROM THE DATE OF SALE TO THE ORIGINAL PURCHASER. QA1 MAKES NO OTHER WARRANTY OF ANY KIND, EXPRESS OR IMPLIED. QA1 SHALL HAVE NO OBLIGATION UNDER THE FOREGOING WARRANTY WHERE THE DEFECT IS THE RESULT OF IMPROPER OR ABNORMAL USE, YOUR NEGLIGENCE, VEHICLE ACCIDENT, IMPROPER OR INCORRECT INSTALLATION OR MAINTENANCE, NOR WHEN THE PRODUCT HAS BEEN REPAIRED OR ALTERED IN ANY WAY. QA1'S LIABILITY IN THE CASE OF DEFECTIVE PRODUCTS SUBJECT TO THE FOREGOING WARRANTY SHALL BE LIMITED TO THE REPAIR OR REPLACEMENT, AT QA1'S OPTION, OF THE DEFECTIVE PRODUCTS.

THE USER UNDERSTANDS AND RECOGNIZES THAT RACING PARTS, SPECIALIZED STREET ROD EQUIPMENT, AND ALL PARTS AND SERVICES SOLD BY QA1 ARE EXPOSED TO MANY AND VARIED CONDITIONS DUE TO THE MANNER IN WHICH THEY ARE INSTALLED AND USED. QA1 SHALL BEAR NO LIABILITY FOR ANY LOSS, DAMAGE, OR INJURY, EITHER TO A PERSON OR TO PROPERTY, RESULTING FROM THE INSTALLATION, DIRECT OR INDIRECT USE OF ANY QA1 PRODUCTS, OR INABILITY BY THE BUYER TO DETERMINE PROPER USE OR APPLICATION OF QA1 PRODUCTS. EXCEPT FOR THE LIMITED LIABILITY WARRANTY SET FORTH ABOVE, QA1 SHALL NOT BE LIABLE FOR ANY CLAIMS, DEMANDS, INJURIES, DAMAGES, ACTIONS, OR CAUSES OF ACTION WHATSOEVER TO BUYER ARISING OUT OF OR CONNECTED WITH THE USE OF ANY QA1 PRODUCTS. MOTORSPORTS ARE DANGEROUS; AS SUCH, NO WARRANTY OR REPRESENTATION IS MADE AS TO THE PRODUCT'S ABILITY TO PROTECT THE USER FROM INJURY OR DEATH. THE USER ASSUMES THAT RISK!

DEDICATED TECH SUPPORT

QA1 is dedicated to providing quality support and instructions. We employ passionate racers and car enthusiasts that know our products and the industry to better serve you.

CHECK US OUT ON YOUTUBE!



- Frequently Asked Questions
- Quick Tips
- Install Information
- Tuning and Repair Guides
- Other Technical Information

youtube.com/qa1tech



 linkedin.com/company/qa1
 instagram.com/qa1motorsports
 facebook.com/qa1motorsports

www.qa1.net/tech